

Predator™ II Cellular Media Filter System Kit Owners Manual

IMPORTANT SAFETY INSTRUCTIONS
READ AND FOLLOW ALL INSTRUCTIONS
SAVE THESE INSTRUCTIONS



Important Notice



Attention Installer.

This manual contains important information about the installation, operation and safe use of this product. This information should be given to the owner/operator of this equipment.

▲ WARNING

Before installing this product, read and follow all warning notices and instructions accompanying this filter. Failure to follow safety warnings and instructions can result in severe injury, death, or property damage. Call (800) 831-7133 for additional free copies of this manual.

Pentair Pool Products

1620 Hawkins Ave., Sanford, NC 27330 • (919) 566-8000
10951 West Los Angeles Ave., Moorpark, CA 93021 • (805) 553-5000



Because reliability matters most

Table of Contents

SECTION I.	PUMP SAFETY INSTRUCTIONS	2
SECTION II.	HOW YOUR FILTER WORKS	3
SECTION III.	INSTALLATION	4
SECTION IV.	INITIAL START-UP AND RESTART INSTRUCTIONS	5
SECTION V.	CLEANING FILTER.....	6
SECTION VI.	WINTERIZING THE FILTER	7
SECTION VII.	TROUBLE SHOOTING	8
SECTION VIII.	PUMP INSTRUCTIONS.....	8
SECTION IV.	TECHNICAL DATA	10, 11

SECTION I. PUMP SAFETY INSTRUCTIONS

When installing and using this electrical equipment, basic safety precautions should always be followed, including the following:

1. READ AND FOLLOW ALL INSTRUCTIONS.
2. WARNING - To reduce the risk of injury, do not permit children to use this product unless they are closely supervised at all times.
3. WARNING - Risk of Electrical Shock. Connect only to a grounding type receptacle protected by a ground-fault circuit-interrupter (GFCI). Contact a qualified electrician if you cannot verify that the receptacle is protected by a GFCI.
4. Do not bury the electrical cord. Locate the cord to minimize the abuse from lawn mowers, hedge trimmers, and other equipment.
5. WARNING - To reduce the risk of electric shock, replace damaged cord immediately.
6. WARNING - To reduce the risk of electrical shock, do not use an extension cord to connect unit to electric supply; provide a properly located outlet.
7. CAUTION - For continued protection against possible electric shock, this unit is to be mounted to the base in accordance with the installation instructions.
8. SAVE THESE INSTRUCTIONS.

⚠ WARNING	
	To reduce the risk of electrical shock, only connect to a GFCI protected receptacle. Failure to do so could result in an electrical shock to pool users, installers, or others which can result in serious personal injury or death.

▲ WARNING



THIS FILTER OPERATES UNDER HIGH PRESSURE. WHEN ANY PART OF THE CIRCULATING SYSTEM (e.g., LOCK RING, PUMP, FILTER, VALVES, ETC.) IS SERVICED, AIR CAN ENTER THE SYSTEM AND BECOME PRESSURIZED. PRESSURIZED AIR CAN CAUSE THE LID TO BE BLOWN OFF WHICH CAN RESULT IN SEVERE INJURY, DEATH, OR PROPERTY DAMAGE. TO AVOID THIS POTENTIAL HAZARD, FOLLOW THESE INSTRUCTIONS.

- 1. BEFORE REPOSITIONING VALVES AND BEFORE BEGINNING THE ASSEMBLY, DISASSEMBLY, OR ADJUSTMENT OF THE LOCK RING OR ANY OTHER SERVICE OF THE CIRCULATING SYSTEM: (A) TURN THE PUMP OFF AND SHUT OFF ANY AUTOMATIC CONTROLS TO ENSURE THE SYSTEM IS NOT INADVERTENTLY STARTED DURING THE SERVICING; (B) OPEN AIR RELIEF VALVE; (C) WAIT UNTIL ALL PRESSURE IS RELIEVED.**
- 2. WHENEVER INSTALLING THE FILTER LOCK RING FOLLOW THE CLEANING FILTER INSTRUCTIONS EXACTLY.**
- 3. ONCE SERVICE ON THE CIRCULATING SYSTEM IS COMPLETE FOLLOW INITIAL START-UP AND RESTART INSTRUCTIONS EXACTLY.**
- 4. MAINTAIN CIRCULATION SYSTEM PROPERLY. REPLACE WORN OR DAMAGED PARTS IMMEDIATELY (e.g., lock ring, pressure gauge, relief valve, O-rings, etc.).**
- 5. BE SURE THAT THE FILTER IS PROPERLY MOUNTED AND POSITIONED ACCORDING TO INSTRUCTIONS PROVIDED.**

SECTION II. HOW YOUR FILTER WORKS

Your cellular media filter is designed to produce clear, sparkling water and operate for years with a minimum of maintenance when installed, operated and maintained in accordance with these instructions.

Your filter uses a cellular media cartridge element to remove dirt particles from the water. Dirt is collected in the filter by the cellular media element as water flows through the filter. Water enters the filter through the filter inlet port and is distributed evenly through the cellular media element. The dirt is removed by the cellular media fabric and the clean water flows through the filter outlet port and is returned to the pool through the piping or hoses.

After a period of time, dirt will accumulate in the filter causing a resistance to the flow of water through the filter. This resistance results in a diminished flow of water and a rise in the filter pressure. Eventually the filter will have removed so much dirt and the filter pressure risen to such a point that it will be necessary to clean your filter, see Section V, Cleaning the Filter.

The filter's function is to remove suspended matter from the water, but it does not sanitize the water. For sparkling clear water, the water must be sanitized as well as balanced. Pool chemistry is a specialized area, and you should consult your local pool service specialist for specific details. In general, proper pool sanitation requires a free chlorine level of 1 to 2 PPM and a PH range of 7.2 to 7.6.

⚠ WARNING

Failure to operate your filter system or inadequate filtration can cause poor water clarity, obstructing visibility in your pool. Poor water clarity may obscure objects in the water which, while swimming and diving, could cause severe personal injury and death. Never swim in a pool with poor water clarity.

SECTION III. INSTALLATION

To install this filter system, you will need the following tools - a screwdriver, wrench, and pliers.

(Refer to photo on front page for completed assembly)

1. Carefully remove the equipment from the carton and check for any evidence of damage due to rough handling or shipping. If any of the equipment is damaged, immediately notify the organization where the equipment was purchased.
2. This filter should be mounted on a level concrete slab, or on a platform constructed of concrete block or brick.
3. Position the mounting base on the slab so when the pump is mounted, the front (suction port) of the pump is directly in-line with the skimmer suction port from the pool.
4. Once the pump location is determined, fasten the pump to the base using two bolts and retaining nuts.
5. Add three complete wraps of plumber's tape to the threads of the hose adapters, see Figure 1, and the threaded ends of the pump connector, see Figure 2 and 2A. The tape is included in the kit.

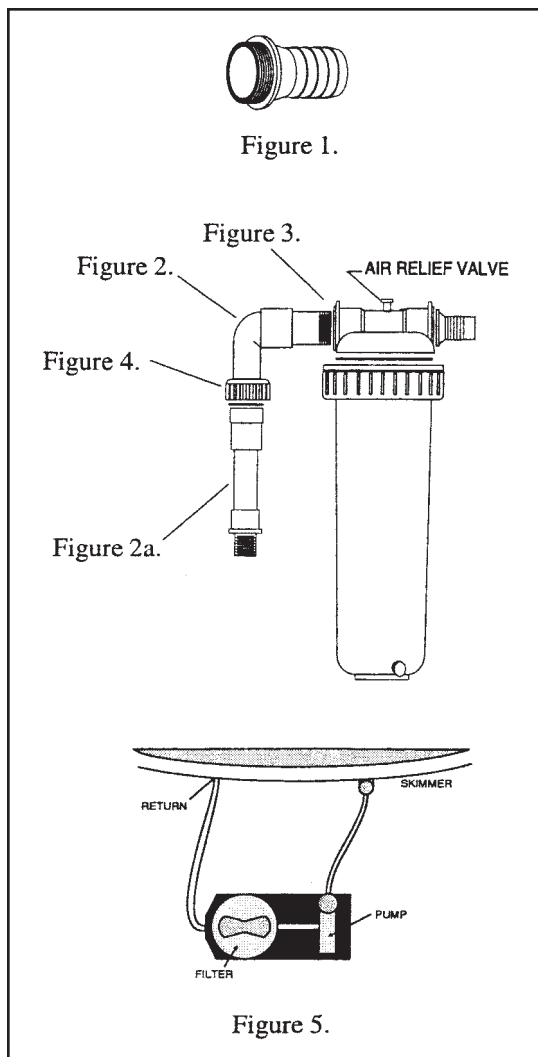

WARNING



This filter operates under high pressure. When any part of the circulating system (e.g., lock ring, pump, filter, valves, etc.) is serviced, air can enter the system and become pressurized. Pressurized air can cause the lid to be blown off which can result in severe injury, death, or property damage.

6. Thread the pump connector, see Figure 2, into the **inlet** port of the filter, see Figure 3, hand tighten with an additional 1/2 turn using a wrench until the end of the connector with the union nut is facing down.
7. Install the O-ring, see Figure 4, into the groove of the pump connector end.
8. Thread the pump connector, see Figure 2a, into the pump outlet port, hand tighten with an additional 1/2 turn using a wrench.
9. Attach the filter and pump connector assemblies together. This is an O-ring seal and requires hand tightening only.
10. Screw in the hose adapters into the filter outlet port and the pump suction port, hand tighten an additional 1/2 turn with a wrench.
11. Slide the clamps over the ends of the hoses. Slide the hoses over the hose adapters and tighten clamps.
12. Attach the opposite ends of the hoses, see Figure 5, to the skimmer suction port and the pool's return inlet fitting port and tighten clamps.

CAUTION

Do not mount electrical controls (on/off switches, timer, etc.) over the filter. You need to be able to stand clear of the filter when starting the pump.

Never install a pump in this system that exceeds the maximum pressure of this filter (see filter data label).

SECTION IV. INITIAL START-UP AND RESTART INSTRUCTIONS

1. Be sure all connections have been made and are secure.
2. **OPEN THE AIR RELIEF VALVE.**
3. **STAND CLEAR OF THE FILTER.** Start pump allowing the filter tank to fill with water. Close the air relief valve after a steady stream of water appears.

4. Your filter has now started its filter cycle. You should check that the water is returning to the pool.
5. Check the system for water leaks. If a leak is found, shut off pump before correcting the leak.
6. As the filter removes the dirt and impurities from the pool water, the accumulation will cause the filter flow to diminish. It is then time to clean the filter's cellular media elements, see Section V, Cleaning the Filter.

WARNING

Failure to operate your filter system or inadequate filtration can cause poor water clarity, obstructing visibility in your pool. Poor water clarity may obscure objects in the water which, while swimming and diving, could cause severe personal injury and death. Never swim in a pool with poor water clarity.

SECTION V. CLEANING THE FILTER

1. Cleaning frequency will vary from pool to pool and with other factors such as weather conditions, heavy rains, dust, pollen, bather load and water chemistry.
2. Turn the pump off, shut off any automatic controls to assure that the system is not inadvertently started during servicing.
3. Plug the skimmer port and water return port with a rag. This will prevent water from the pool from running out while servicing.
4. Open the filter air relief valve, and the filter drain plug.
5. Disconnect the pump connector from the pump.
6. Unscrew the locking ring (turning counter-clockwise) from the filter head.
7. Remove the CELLULAR MEDIA ELEMENT from the filter body.
8. Using a garden hose, direct water spray at the CELLULAR MEDIA ELEMENT to dislodge and wash away any accumulated foreign matter.
9. Clean and remove any debris from inside the filter body.
10. Replace the CELLULAR MEDIA ELEMENT into the filter body.
11. Clean any debris from the O-ring at the top of the filter tank. Apply a silicone lubricant to the O-ring.

DO NOT USE A PETROLEUM-BASE LUBRICANT ON THE O-RING.

▲ WARNING



If the filter lock ring is damaged, replace it immediately.

This filter operates under high pressure. Replace locking ring if damaged or worn. Failure to replace locking ring can result in the lid separating from the filter which can cause severe injury or death.

12. Screw the locking ring (clockwise) onto the filter head.
13. Reconnect the pump connector to the discharge port of the pump.
14. Replace the drain cap, hand tighten only.
15. Follow Initial Start Up and System Restart Instructions.

SECTION VI. WINTERIZING THE FILTER

1. In the areas that have freezing winter temperatures, the pool equipment must be winterized to protect it from damage.
2. With the pump turned off, open the air relief valve.
3. Remove the drain port cap, and allow the filter to drain completely.
4. Remove the drain port plugs on the pump and allow the pump to drain completely.
5. Drain all appropriate system piping.
6. It is recommended that the pump and filter be covered with a tarpaulin or plastic sheet to inhibit deterioration from the weather.

DO NOT WRAP THE PUMP MOTOR WITH PLASTIC.

7. Your filter system is now winterized.
8. See Section IV, Initial Start Up and Restart Instructions when pool is ready to be opened for the season.

SECTION VII. TROUBLE SHOOTING

Problem	Cause	Remedy
Pool water not sufficiently clean	1. Pool chemistry not adequate to inhibit algae growth.	Maintain pool chemistry or consult pool service technician.
	2. Inadequate turnover rate.	Run system for longer time or consult dealer or pool service technician.
Higher filter pressure.	1. Insufficient cleaning of the filter element.	Clean the filter element (see Cleaning Filter instructions).
	2. Partially closed valve or restriction.	Open valve or remove obstruction in return line.
Short filter cycles.	1. Insufficient cleaning of filter element.	Clean the filter element (see Cleaning Filter instructions).
	2. Pool chemistry not adequate in inhibit algae growth.	Maintain pool chemistry or consult pool service technician.
	3. Flow rate too high.	Restrict flow to capacity of filter.
Return flow to pool diminished, low filter pressure.	1. Obstruction in the pump hair and lint pot.	Clean basket in strainer.
	2. Obstruction in pump.	Disassemble and clean pump.
	3. Obstruction in suction line to pump.	Clean skimmer basket. Remove obstruction in lines. Open valves in suction line.

SECTION VIII. PUMP INSTRUCTIONS

1. **TO PRIME PUMP** - (pump must be off). Turn pump off. Place pump at or below the water level of the pool (preferably lower than the pool water level). Open the air relief valve. Allow water to flood the inlet hose and pump housing. Stand clear of the filter and turn the pump on. Close the air relief valve after a steady stream of water appears. The pump will experience a temporary unstable condition and may be somewhat noisy until all air in the system is cleared.

WARNING



To reduce the risk of electrical shock, only connect to a GFCI protected receptacle. Failure to do so could result in an electrical shock to pool users, installers, or others which can result in serious personal injury or death.

⚠ CAUTION

DO NOT RUN PUMP DRY. If the pump is run dry, the mechanical seal will be damaged and external leakage will occur. When a seal is damaged, the seal must be replaced.

⚠ CAUTION

ALWAYS MAINTAIN PROPER WATER LEVEL IN THE POOL. Water level must be half way up the skimmer opening. A low water level can cause the pump motor to run dry which will damage the mechanical seal and cause external leakage.

2. SHAFT SEAL - (rotary seal). The shaft seal consists of two parts:
 - a. Rotating ceramic seal, press fitted into the impeller.
 - b. A stationary spring loaded seal, press fitted into the rear of the volute.

⚠ CAUTION

The highly polished and lapped faces of the seal are easily damaged. Handle with care. This centrifugal pump requires little or no service, however the shaft seal will wear with normal use over the years and will require periodic replacement.

3. THE ELECTRIC MOTOR

- a. The electric motor should be protected from foreign matter, water splashing, hosing, and the weather. Enclosures should be well ventilated to prevent overheating. If a motor becomes wet, permit it to dry before running it. If a motor has been damaged by water or dirt, the warranty is void.
- b. The motors used on these pumps are 48 frame through bolt motors. The through bolts are used to secure the volute to the motor. When replacing the motor, mark the end bells and the motor shell to indicate alignment. Remove the four nuts from the through bolts at the shaft end. Place the shaft through the back of the volute and locate the bolts in line with the brass inserts located in the four legs at the rear of the volute. Be sure the end bell and the shell marking line up. Securely fasten the motor to the volute.
- c. Protect the motor from heat. Provide ample ventilation.

SECTION IX. TECHNICAL DATA

A. FILTER AND TANK

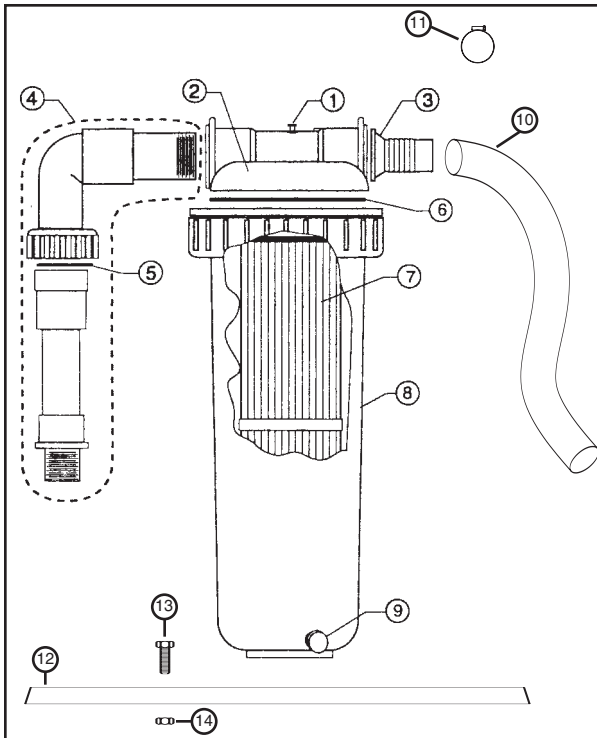

Replacement Parts

Find No.	Part No.	Description	Qty.
1	56208500	Air relief valve	1
2	56208100	Lid	1
3	85004500	Hose adapter	2
4	59019800	Pump connector	1
5	39102800	O-ring	1
6	56208600	O-ring	1
7	56208300	Cartridge	1
8	56208700	Body	1
9	56208400	Drain Plug	1
10	155153	Flexible Hose 1.5"	2
11	711004	Hose Clamp	4
12	98105700	Stand with T Nut 1/4 - 20 x 3/4	1
13	40004500	Bolt Motor to Stand	2
14	071406	Nut Motor to Stand 1/4 - 20 SS	2

B. PUMP

Part number 351233 - Dynamo Pump 3/4 HP, 1 speed with on/off switch.

Electrical Specifications: Branch Circuit: 15 Amps. Volts: 115. HZ: 60. Phase: 1.

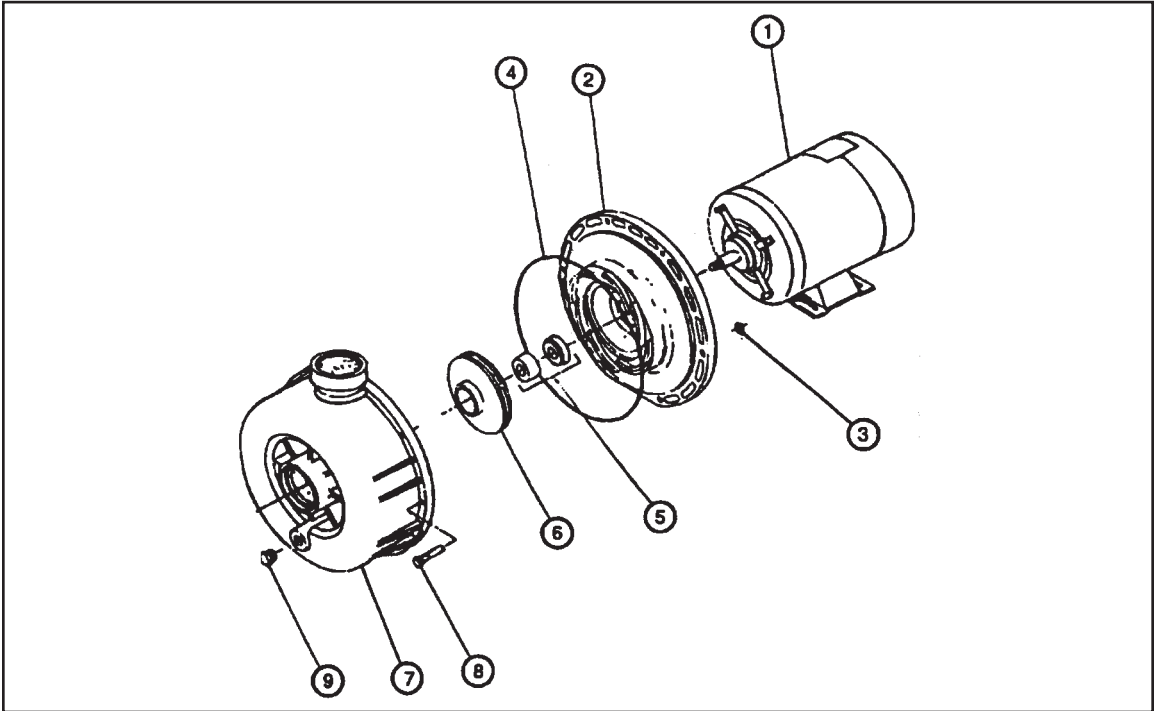

Dynamo Pump Replacement Parts for Predator II System

Item	Part No.	Description	Qty.
1	356597	Motor without cord, 3/4 HP 1 speed with on/off switch	1
	79127700	Electrical cord assembly 3" standard, 115 VAC, 15 AMP	
2	35-4632	Bracket Diffuser 3/4 HP	1
3	35-4542	Square Nut No. 10-24 stainless steel	1
4	35-4634	O-ring, 3/16" pump bracket	6
5	35-4545	Seal-mechanical 5/8"	1
6	35-4552	Impeller assembly 3/4 HP	1
7	35-4630	Housing Body	1
8	35-4541	Screw-slotted hex No. 10-24-1 3/8"	6
9	15-4481	Drain Plug 1/4"	1

READ AND FOLLOW ALL SAFETY INSTRUCTIONS

SAVE THESE INSTRUCTIONS

SAVE THESE INSTRUCTIONS

Pentair Pool Products

1620 Hawkins Ave., Sanford, NC 27330 • (919) 566-8000
10951 West Los Angeles Ave., Moorpark, CA 93021 • (805) 553-5000

