

UNIVERSAL BOOSTER PUMP INSTALLATION

This booster pump is 3/4 horsepower with a 1.5 service factor producing a minimum of 50 psi at 12 GPM.

1. UNIT LOCATION

Pump should be installed on a firm and level surface. Unless required by a local code, it need not be bolted down. Installation should be as close as possible to a filtered water return line and convenient location for servicing. *NOTE: Booster pump must always be connected to return line on discharge side of filter. Never connect suction side booster pump ahead of filter. (See Figure 1).*

2. TYPICAL INSTALLATION - HEATER CONSIDERATION

Suction side of booster pump must be connected to the return line after the heater. Except on solar installation, never connect suction side of booster pump ahead of filter or heater. *NOTE: Keep booster pump a minimum of 3 feet from heater.*

Figure 2A: Installation with Heater

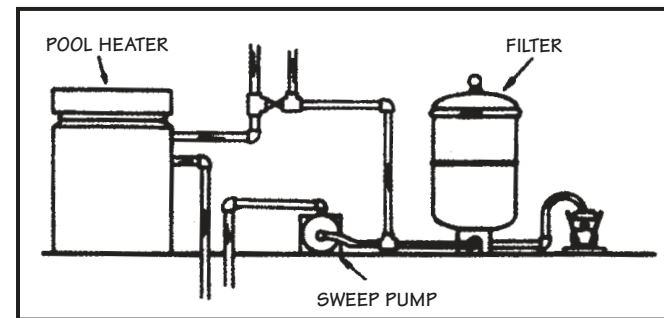

3. INSTALLATION WITH SOLAR HEATER

With or without a gas heater for back-up, when installing any one of Pentair automatic pool cleaners in a pool with solar heating, the in-line tee must be installed on the return line between the filter and the solar heater. This minimizes the possibilities of an air lock in the sweep pump each time the solar panel is filled and assures an ample supply of water. (See Figure 2B).

Figure 2B: Installation with Heater

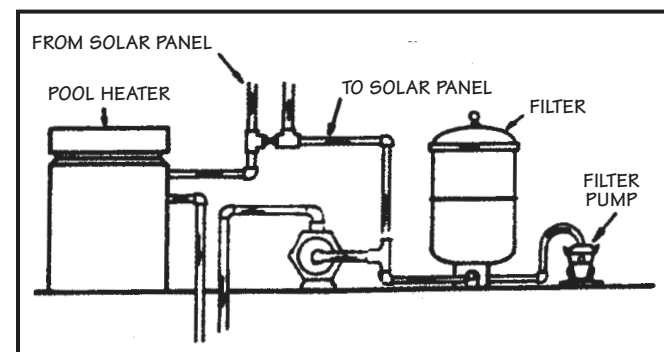

4. INSTALLATION WITH SPA POOLS

Connect suction side of the booster pump before spa bypass valve, if your pool is plumbed for a spa pool. (See Figure 3).

Figure 3: Installation with Pool/Spa Combo

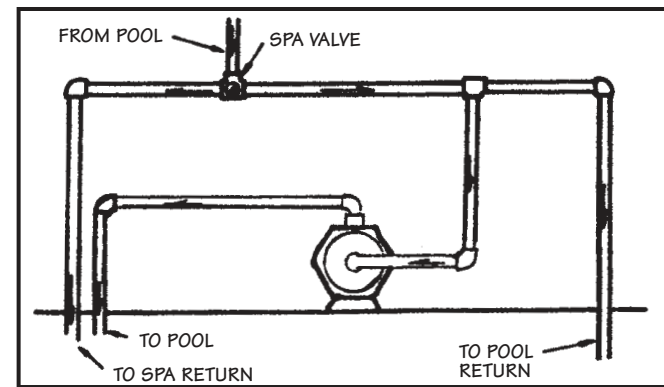

CAUTION: BEFORE MAKING ANY ELECTRICAL CONNECTION TO EXISTING POWER SOURCES, BE SURE ALL ELECTRICAL POWER IS OFF.

5. PUMP INLET CONNECTION TO POOL RETURN LINE

Use elbow and reducing bushing if needed on pre-plumbed installation. Use tee on existing installation. Connect pump suction to the return line after filter and heater as follows: Preferably, underneath side (NEVER ON TOP) of the horizontal return line.

6. INSTALLATION OF PUMP HOSES

- To install hoses remove adapter from hose kit bag (P/N 353020) and wrap thread seal tape around the 3/4 inch npt threads of the adapter. A minimum of four revolutions is required.
- Screw adapter with thread seal tape into the pump outlet. Torque to 60 inch x lbs.
- Cut hose to appropriate length. Six (6) feet of hose has been provided for both the inlet and outlet.
- Place adapter cap over hose (See Figure 4) and slide the hose onto the adapter until the hose is flush against the wall where the threads begin. Heating of the hose or use of a lubricant may be useful if the hose is cold.
- Screw adapter cap and tighten to the adapter to secure the hose. Torque to 60 in. x lbs.
- Repeat process for both inlet and outlet of pump. When routing the hose make sure there are no tight bends or kinks in the hose.

Figure 4: Installation of Pump Hoses

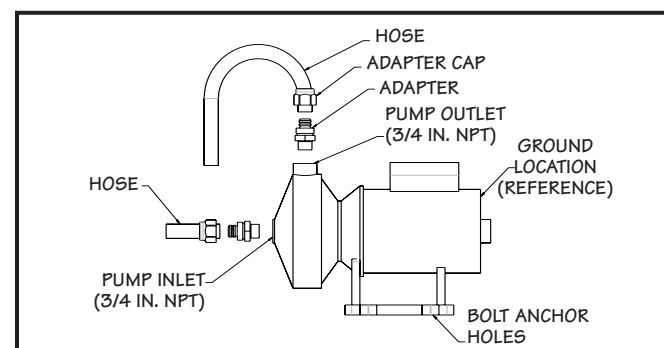

UNIVERSAL BOOSTER PUMP INSTALLATION

7. SPECIFICATIONS

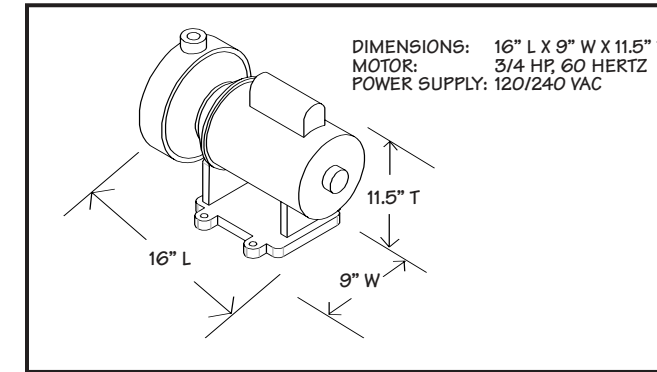

8. ELECTRICAL CONNECTIONS FOR BOOSTER PUMP

Pentair Universal Booster Pump is pre-wired to operate on 230 volts. The motor can also be wired to operate on 115 volts by making a simple modification at motor wire connection plate.

BEFORE TURNING ON POWER TO PUMP, CHECK VOLTAGE AT INTENDED SOURCE BEFORE MAKING ELECTRICAL CONNECTION. PUMP MOTOR CAN BE DAMAGED IF CONNECTED TO WRONG VOLTAGE.

ELECTRICAL WORK SHOULD BE DONE BY A LICENSED ELECTRICIAN.

CHECK ELECTRICAL CODES FOR REQUIREMENTS IN YOUR LOCAL AREA.

9. SAFETY WARNING

Motor frame should be grounded for swimming pool installations as specified in Article 680 of the National Electrical Code. Failure to properly ground motor can result in serious electrical shock.

10. TIME CLOCK

A separate time clock is recommended. To ensure proper sequence of filter pump and booster pump, the time clocks must be reset if power is interrupted.

The automatic pool cleaner must be run for a length of time necessary to clean the pool, but should never be allowed to run while filter system is off. This will result in damaging the booster pump. Running the automatic pool cleaner without the filter system in operation will void warranty. The automatic pool cleaner should start operating one half hour to forty-five minutes after the filter pump starts and stop one half hour to forty-five minutes before the filter pump stops.

11. MANUAL SWITCH

A manual switch is recommended. It should be located between the time clock and the booster pump. This switch eliminates turning the pump off at the time clock.

12. PUMP SEAL

The booster pump is fitted with a mechanical shaft seal which is water lubricated and water cooled. If the pump is run without water this seal will be damaged. **NEVER OPERATE UNLESS FILTER SYSTEM IS ON.**

13. SERVICING THE BOOSTER PUMP

Note: This motor is a drip proof motor, but can be damaged by rainfall, splash or flooding by causing water to enter the motor.

- To disassemble the booster pump -

- Turn off booster pump motor and close valves.
- Unscrew suction line in middle of volute.
- Loosen nuts and remove bolts between booster pump volute and seal bracket.
- On back end of motor remove cap. Use a crescent wrench or open end wrench to hold shaft from spinning.
- Hold wrench and turn impellar counter clockwise to remove.

- To remove seal -

- Stand motor on end, using one screwdriver slowly pry seal out of impellar. Remove seal bracket and dislodge seal from backside of seal bracket using hammer and screwdriver.

- To re-assemble the unit -

- After replacing the necessary parts, re-assemble by reversing order of steps 1-5 above.
- Ceramic seat must be perfectly clean of any foreign objects or dirt. If seat is not clean, it will cause leakage. The ceramic seat must go in with the side containing grooves facing into the center of the rubber gasket, otherwise it will leak.
- Replace impellar and seals if warped or discolored. This condition is caused by overheating due to pump running dry. Smooth surface of ceramic seal should be parallel to and facing away from back side of impellar.
- Silicone backside of metal flange on spring seal, push down until flush in center of seal bracket. Be careful not to get silicone on to spring seals contact surface.

If you have any questions, contact Pentair Pool Products at 1-800-831-7133

UNIVERSAL BOOSTER PUMP INSTALLATION

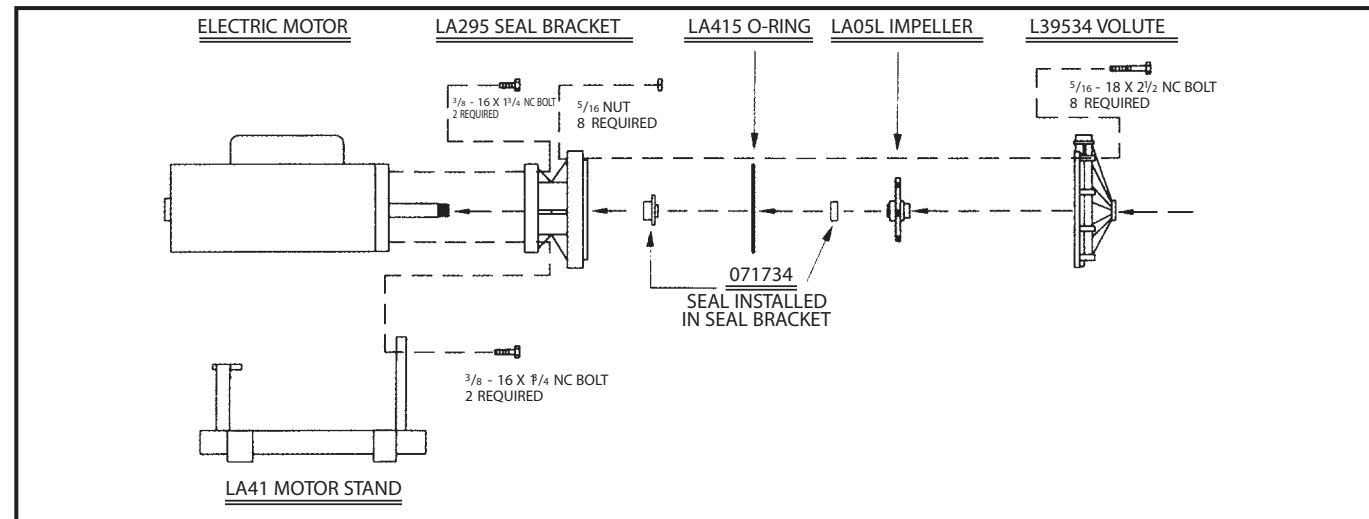

UNIVERSAL BOOSTER PUMP INSTALLATION AND PARTS LIST



IMPORTANT

A solid copper bonding conductor not smaller than No. 8 AWG (8.4 mm²) should be connected from the accessible wire connector on the motor to all metal parts of the swimming pool, spa, or hot tub structure and to all electrical equipment, metal conduit and metal piping within 5 ft. (1.5m) of the inside walls of a swimming pool, spa or hot tub when the motor is installed within 5 feet of the inside walls of the swimming pool, spa or hot tub.

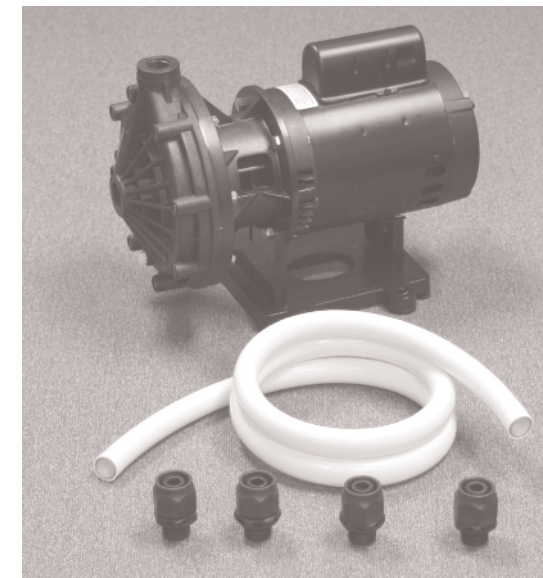

Qty.	Description:	Part #	Qty.	Description:	Part #
8	Bolts	LA115	1	O-Ring for Drain Plug	PA375
8	Nuts	LA125	1	Drain Plug	LA385
1	Seal	071734	1	O-Ring	LA415
1	Impeller	LA05L	2	Bolts 3/8 - 16x3/4 NC	LA135
1	Motor Stand	LA41	4	Grommets	MA36
1	Volute	LA39534	2	Grommets	MA36S
1	Seal Bracket	LA295	2	Bolts 3/8 - 16x11/14 NC	LA136
1	Hose Kit	353020			

**IMPORTANT SAFETY INSTRUCTIONS.
READ AND FOLLOW ALL INSTRUCTIONS CAREFULLY.
SAVE THESE INSTRUCTIONS.**

Figure 1: Typical Installation

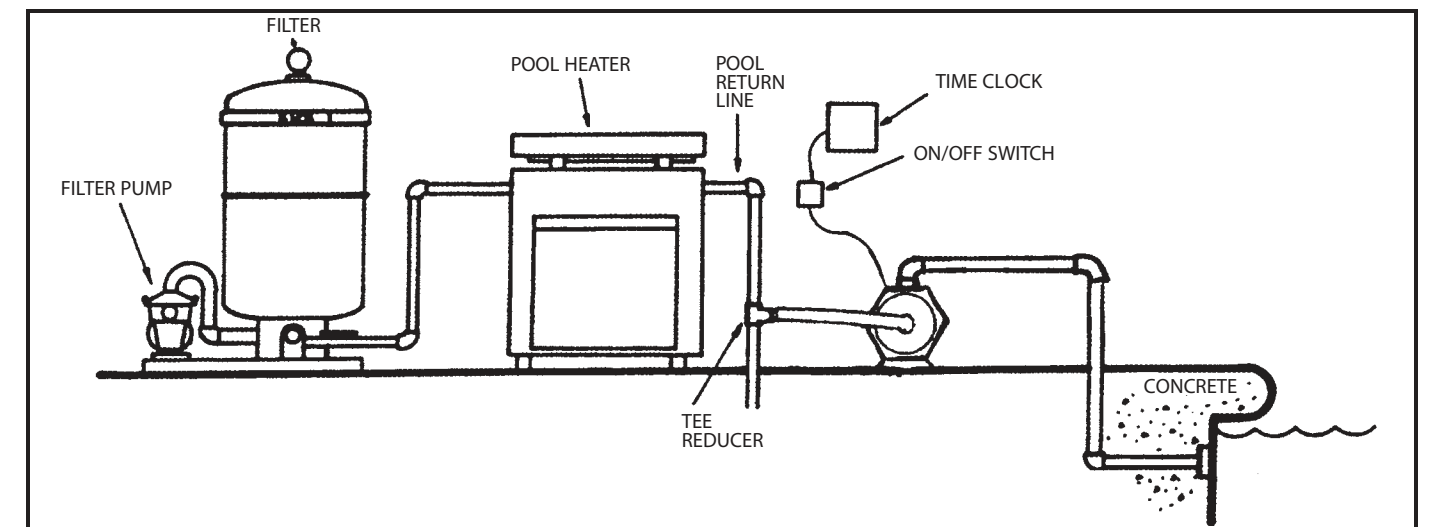

WATER SOLUTIONS

1620 HAWKINS AVE., SANFORD, NC 27330 • (919) 566-8000
10951 WEST LOS ANGELES AVE., MOORPARK, CA 93021 • (805) 553-5000
WWW.PENTAIRPOOL.COM

All Pentair trademarks and logos are owned by Pentair, Inc. Pentair Aquatic Systems™ is a trademark of Pentair Water Pool and Spa, Inc. and/or its affiliated companies in the United States and/ or other countries. Unless expressly noted, names and brands of third parties that may be used in this document are not used to indicate an affiliation or endorsement between the owners of these names and brands and Pentair Water Pool and Spa, Inc. Those names and brands may be the trademarks or registered trademarks of those third parties. Because we are continuously improving our products and services, Pentair reserves the right to change specifications without prior notice. Pentair is an equal opportunity employer.

© 2012 Pentair Aquatic Systems. All rights reserved. This document is subject to change without notice.
P/N YYA3 REV. D 6/29/12